

Shake it baby **Twist** and shout!



The new *Kwik Twist* range for easier, faster Infrared scanning

The brand new Kwik Twist (KT) range from Hawk IR is designed to enable easier and faster access when performing Infrared or visual inspections. Standard Sightglasses require a security screw to be removed in order to pivot round the protective cover, with the new KT Covers the security screws need only be slackened a half turn before the magnetic cover can be quickly removed.

Kwik Twist covers are available separately for backwards compatibility with all existing Hawk IR Sightglasses. The complete KT range can now be ordered directly from Hawk IR and its distributors. To find out more please contact a Hawk IR distributor today!

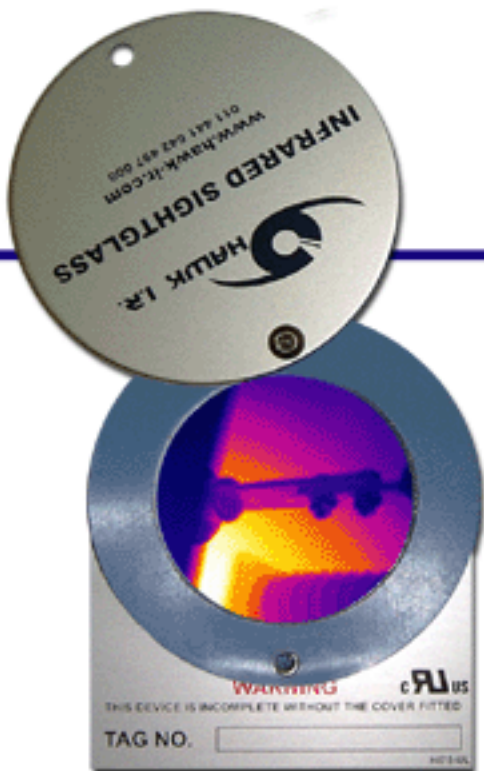

Hawk IR International Ltd.
 117 High Street, Marske by sea, Cleveland
 TS11 6JX, United Kingdom
 Tel: +44 (0) 1642 497000 • Fax: +44 (0) 1642 497111
 e-mail: sales@hawk-ir.com • www.hawk-ir.com



C-RANGE

INFRARED SIGHTGLASSES

**NOW AVAILABLE FOR
ZONE 1 HAZARDOUS AREAS**

MOTORS



TRANSFORMERS



SWITCHGEAR



- **SAFE-** 40kA ARC-FLASH TESTED
Successfully Arc-flash tested to a maximum of 40kA. Testing carried out to both IEEE C37 and IEC62271-200 for worldwide compliance.
- **RUGGED-** NEMA TYPE 3/12 & IP65 RATED
Certified by UL, SIRA and Lloyds of London for installation into both indoor and outdoor equipment
- **FLEXIBLE-** BROADBAND CRYSTAL OPTIC
Broadband optic suitable for all IR cameras uses the CLIRVU® coating system, providing flexibility and longevity. Only Hawk IR can provide a lifetime guarantee on the CLIRVU® coated crystal optics.
- **SECURE-** SAFE INSTALLATIONS
Unique mounting system allows for safe, single person installation & retro-fitting with NO dangerous internal fasteners required.

The only IR Sightglass endorsed by



THE INFRARED SIGHTGLASS PEOPLE

FIELD OF VIEW

Equal to six times the cabinet depth (F=Dx6)

Section through control cabinet Hawk I.R. shown open.

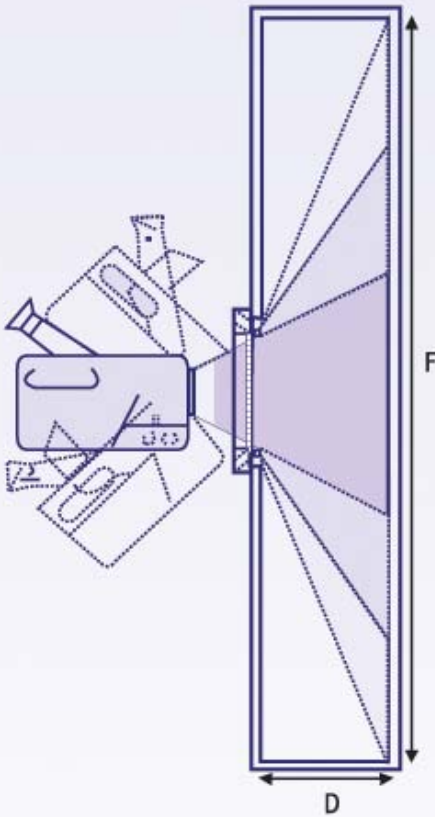

EXPLODED VIEWS

- A Security Screws
- B Aluminium Cover
- C Front Gasket
- D Fixing Screws
- E Complete Sightglass Housing

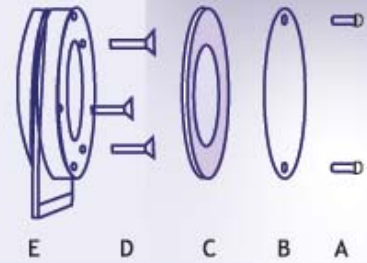

PRODUCT SERIAL CODE

Format: HWK=BBB=C=D=E
E.g. HWK-075-C-L (A 3" C-Type Unit with LSF Gaskets)

HWK-Prefix denoting Hawk I.R. product (generic)

BBB (SIZE)

- 050=<2" Crystal Insert size
- 075=<3" Crystal Insert Size
- 100=<4" Crystal Insert Size

C (VIEWING MATERIAL)

C=C-Type I.R. Material

D (GASKET MATERIAL)

L=LSF (Low Smoke & Fume)

E (KWIK-TWIST OPTION)

KT=Kwik-Twist (Magnetic cover)

LENS

C Type

Solubility	-CLIRVU® Coated Crystal (Totally insoluble)
Thickness	-0.081"
Pressure withstand	-Upto 90psi
Melting Temperature	-1350C/2474F
I.R. Transmission	-Upto 96%
Wavelength	-0.13 to 10.0 micrometers

Other crystal types available

INGRESS PROTECTION

IP 65 CERTIFIED BSEN60529
UL Recognised for NEMA 3/12 equipment

FIXING SCREWS

Stainless Steel

PROTECTIVE COVER

Aluminum

FRAME

Aluminum to BS6082-T6
Anodised to DEF STAN 03-25/3 aa 8-13

GASKETS (Other materials available)

LSF -94°F to +482°F

FOOTPRINT DIMENSIONS

Type	A	B
050	2.6"	3.5"
075	4"	4.9"
100	4.9"	6"

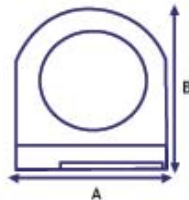

ACTUAL DIMENSIONS

Type	A	B	C
050	2.5"	0.7"	1.7"
075	4"	0.7"	2.7"
100	4.9"	0.75"	3.5"

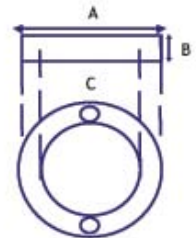

HAWK I.R. International Ltd.
US Contact Tel: 1-877-4-HAWKIR
UK Contact Tel: +44(0)1642 497000
Email: sales@hawk-ir.com
Web: www.hawk-ir.com



Hawk IR Sightglasses are manufactured by Cockburn Thermal Imaging Ltd an ISO9000 registered infrared window manufacturer.

US Toll free number 1-877-4-HAWKIR

SIGHTGLASS DATASHEET C-RANGE



M-RANGE

INFRARED PORT

SWITCHBOARDS



MCC's



TRANSFORMERS



- **SAFE- FINGERPROOF**
<6mm (1/4") Hole pattern complies with IEC and ANSI 12mm (1/2") maximum enclosure openings restriction
- **HIGH VALUE- NEMA TYPE 1 & IP2X RATED**
Recognized by UL for installation into NEMA/UL50 Type 1 & IP2X INDOOR, LOW VOLTAGE equipment.
- **LOW COST- NO CRYSTAL OPTIC REQUIRED**
M-Range is intended for indoor, low voltage equipment. As such, high strength crystal optic materials are not required, keeping costs down.
- **EFFICIENT- NO SPECIAL LENSES REQUIRED**
M-Range Infrared Ports operate with all Infrared Cameras. No Proprietary Lens options are required

The only IR Sightglass
endorsed by
FLIR
SYSTEMS INC.

THE INFRARED SIGHTGLASS PEOPLE



FIELD OF VIEW

Equal to six times the cabinet depth (F=Dx6)

Section through control cabinet Hawk I.R. shown open.

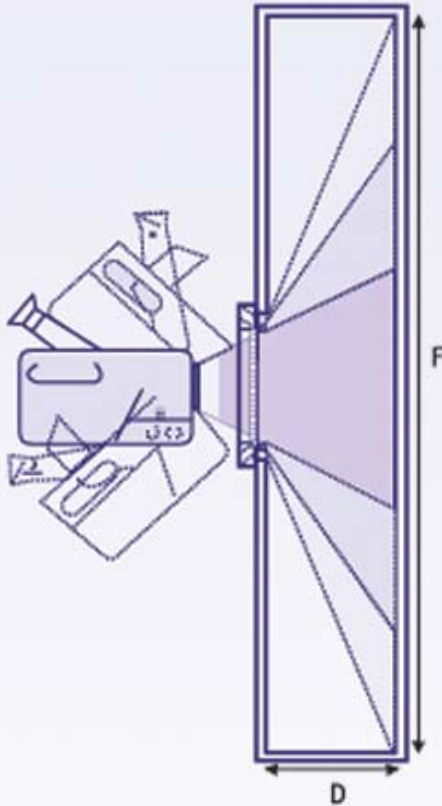

FRAME

Aluminum to BS6082-T6
Anodised to DEF STAN 03-25/3 aa 8-13

GASKETS (Other materials available)
LSF -94°F to +482°F

EXPLODED VIEWS

- A Security Screws
- B Aluminum Cover
- C Front Gasket
- D Fixing Screws
- E Complete Sightglass Housing

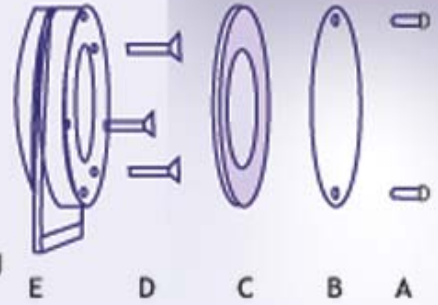

PRODUCT SERIAL CODE

Format: HWK=BBB=C=D=E
E.g. HWK-075-M-L (A 3" M-Type Unit with LSF Gaskets)

HWK- Prefix denoting Hawk I.R. product (generic)

BBB (SIZE)

050=<2" Mesh Insert size
075=<3" Mesh Insert Size
100=<4" Mesh Insert Size

C (VIEWING MATERIAL)

M=M-Type I.R. Material

D (GASKET MATERIAL)

L=LSF (Low Smoke & Fume)

E (KWIK-TWIST OPTION)

KT=Kwik-Twist (Magnetic cover)

LENS

Solubility
Thickness
Individual Opening Diameter
Air gap

-N/A Anodised Mesh optic
-0.081" (2mm)
-5mm(<1/4")
-Approximately 79%

INGRESS PROTECTION

IP65 (CLOSED) IP2X (OPEN) to BSEN60529
UL Recognized for NEMA 1 equipment

FIXING SCREWS

Stainless Steel

PROTECTIVE COVER

Aluminum

FOOTPRINT DIMENSIONS

Type	A	B
050	2.6"	3.5"
075	4"	4.9"
100	4.9"	6"

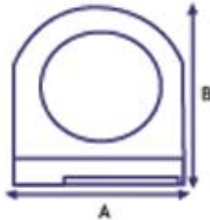

ACTUAL DIMENSIONS

Type	A	B	C
050	2.5"	0.7"	1.7"
075	4"	0.7"	2.7"
100	4.9"	0.75"	3.5"

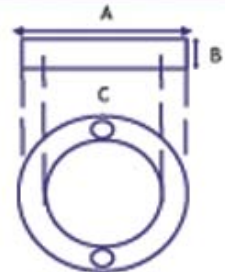

HAWK I.R. International Ltd.
US Contact Tel: 1-877-4-HAWKIR
UK Contact Tel: +44(0)1642 497000
Email: sales@hawk-ir.com
Web: www.hawk-ir.com

US Toll free number 1-877-4-HAWKIR



Hawk IR Sightglasses are manufactured by Cockburn Thermal Imaging Ltd an ISO9000 registered infrared window manufacturer.

SIGHTGLASS DATASHEET M-RANGE